



Products catalog

Polish manufacturer of high-quality food smokers.







Borniak

State-of-the-art technology, easy to operate combined with the unmistakable taste of smoking with wood, awaits your smoked food in our Borniak smoking cabinets. Constant temperatures, perfect insulation and always a consistent, excellent smoke paired with low operating costs make our smokers so unique. Hot smoking and cold smoking at up to 150 °C opens countless smoking variations in the creation of your own food.

Whether you're a beginner or professional, angler, hunter or BBQ fan who is looking for top smoking results, look no further.

Meat, fish, poultry, cheese, vegetables or for the making ham and sausages, etc. the Borniak Smoker can do it all.

Electric Smokers with smoke generator

Perfect for beginners and professionals

Doesn't matter if it's smoked cheese, fish, meat or vegetables, lunch or dinner with the family – Borniak's smoker cabinet makes smoking easy and a pleasure for everyone.

The unit can keep temperature and smoke constant for any length of time. In the automatic smoke generator, the wood chips are transported via a spiral spring and ignited with an electric heating rod. Thanks to this special technique from Borniak, a particularly gentle smoking process with high-quality smoke is possible. In this way, the smoked food is not only particularly tasty, but also, just like in the old days, perfectly preserved.

Easy to use and efficient. Our smokers are also particularly suitable for the popular "low and slow" barbecue due to the long time in the smoker at low temperatures.

You can easily create the US BBQ classics such as Ribs, Pulled Pork and Brisket.

Always a perfect smoke

The whole process of producing smoke comes down to the single push of a button – all thanks to our patented smoke generator. The generator works so that the chips are smoldering to produce clean smoke. They slowly travel from the generator's container, over a heating rod that gradually burns them.

What should be emphasized?

No flame means no soot. Because of the unique smoke generator, only clean smoke comes into contact with your food.

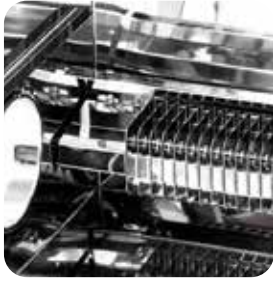

Heater & heat sink

The smoker gets to temperature using a heater equipped with a heat sink. This ensures effective temperature distribution throughout the unit.



Temperature & Timer

Our electronic thermostat allows for accurate temperature control and is easy to adjust with the dial. Various timer functions are also accessible on the panel.



Drip Tray

A baffle, with specially shaped openings separates the working space from the smoking space – so that fats and juices do not run down onto the heating elements or smoldering wood.



Safety

Top drip tray protects the contents of the smoker from anything dropping from the chimney.



Adjusting smoke

The chimney has a damper that allows you to regulate the smoke density. Thanks to this, you can adjust the smoke intensity to your recipe.



Hinges

Strong, robust hinges to keep the door secured to the body.



Magnetic closure

The chamber door has a magnetic closure, additionally insulated with a gasket. This ensures an exceptionally tight seal with minimal smoke/heat loss.



Adjustable feet

Strong professional adjustable feet with non-slip rubber



Smoke generator

The entire process of producing smoke comes down to pressing a button.



Cold Smoke (option)

The cold smoking adapter allows you to smoke at low temperatures. (at least 1-2oC higher than atmospheric)



Wheels (option)

If your smoker does not have a permanent place or you need to move it quickly, this is a must-have accessory.



Accessories (option)

Many other accessories are available that are useful when using the smoker.

Classic Smoker 70 TIMER UWDT-70v1.4



10 kg meat



6 kg fish



6 kg sausages



6 levels



120°C max temp.



Alu-zynk



Timer



Stainless steel



Classic Smoker 150 TIMER UWDT-150v1.4



20 kg meat



14 kg fish



14 kg sausages



7 levels



120°C max temp.



Alu-zynk



Timer



Stainless steel





Classic Smoker 70 SIMPLE

UWD-70v1.4



10 kg meat



6 kg fish



6 kg sausages



6 levels



120°C max temp.



Alu-zynk



Simple



Stainless steel



Classic Smoker 150 SIMPLE

UWD-150v1.4



20 kg meat



14 kg fish



14 kg sausages



7 levels



120°C max temp.



Alu-zynk



Simple



Stainless steel

Smoker BBQ 70 TIMER BBDST-70v1.4



10 chickens*



5 ribs*



40 sausages*



6 levels



150°C max temp.



Polished stainless steel



Timer



Stainless steel

*The estimated quantity depends on the size of the product.



Smoker BBQ 150 TIMER BBDST-150v1.4



20 chickens*



10 ribs*



80 sausages*



7 levels



150°C max temp.



Polished stainless steel



Timer



Stainless steel

*The estimated quantity depends on the size of the product.





Smoker BBQ 70 SIMPLE BBDS-70v1.4



10 chickens*



5 ribs*



40 sausages*



6 levels



150°C max temp.



Polished stainless steel



Simple



Stainless steel

*The estimated quantity depends on the size of the product.



Smoker BBQ 150 SIMPLE BBDS-150v1.4



20 chickens*



10 ribs*



80 sausages*



7 levels



150°C max temp.



Polished stainless steel



Simple



Stainless steel

*The estimated quantity depends on the size of the product.

Borniak Simple

The digital control system is responsible for maintaining a constant temperature. Simply set the desired temperature. The controller works according to the prediction principle, which allows us to rely on a constant temperature in the smoker.



Borniak Timer

Our easy-to-use Timer Controller Panel has been specially designed and developed for our Borniak smoker.

As in the predecessor "Simple" version, the temperature in the smoker is maintained on an algorithmic prediction basis. As a result, we achieve a constant temperature during smoking.

The timer functions that the new controller is equipped with allow us to set the time for a specific function.

For example, the heating time of the radiator, the time in which the smoke is produced or the drying (optional accessory). Using the device is now much easier.

You can specify to the minute how long your food is in the smoke.



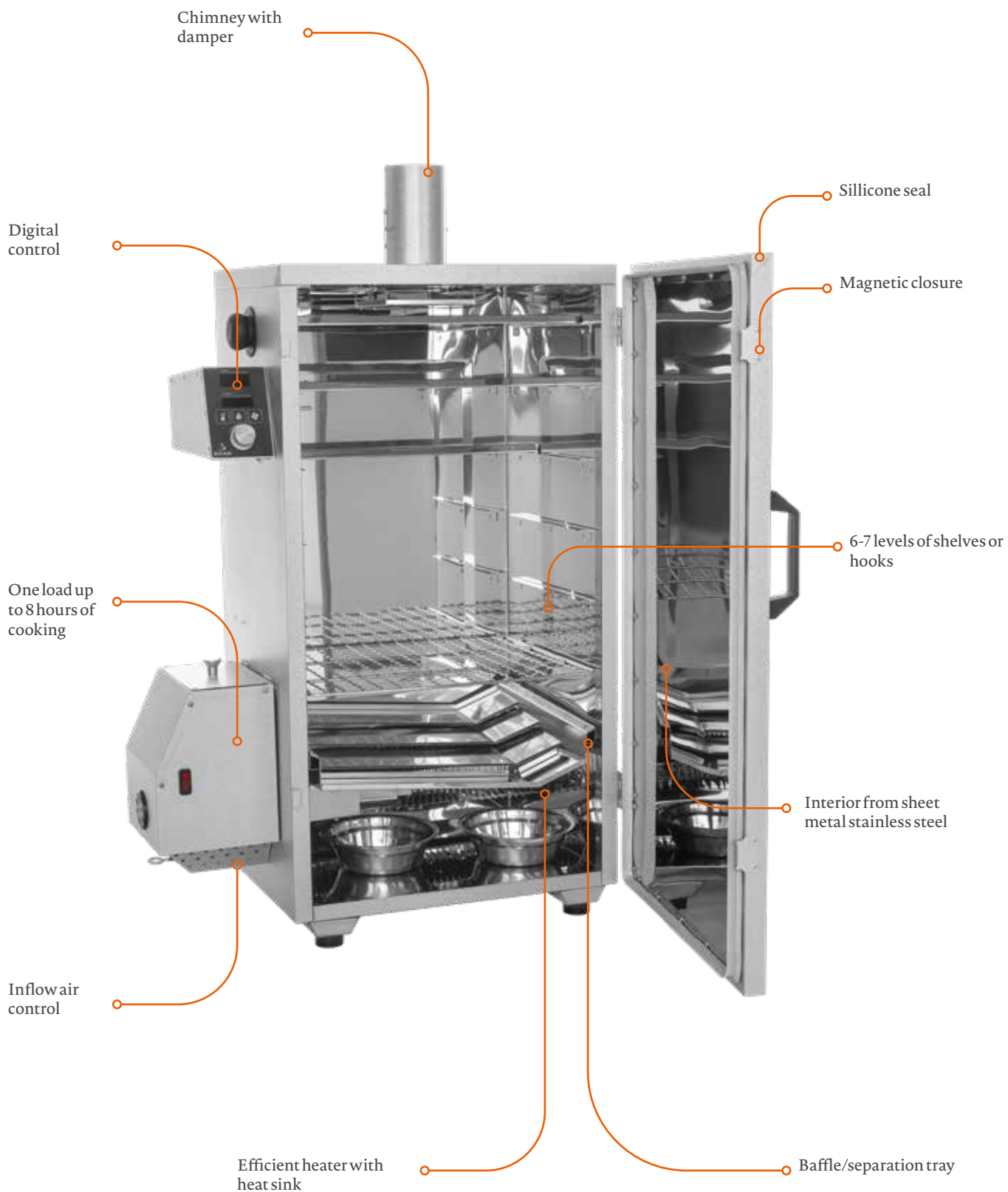





Smoke Generator

Wouldn't it be nice to prepare delicious smoked food without continuously controlling the smoke and temperature? No problem with this smoke generator specially developed and patented by Borniak. The automatic smoke generator ensures that the wood chips burn evenly, guaranteeing constant, optimal smoke development.

The smoke generator was created to be used with the Borniak smoker, but it can be used with other devices, as long as they have the appropriate fixing. The device works with chambers with a capacity of up to 200L.

GDS-01 / GD-01

- keep smoke constant!
- up to 8 hours of constant, optimal smoke development without adding wood chips
- can be used for a wide variety of smokers
- can be used for smokers with a volume of up to 200 liters
- built-in slider to regulate the air supply
- polished stainless steel (GDS-01)

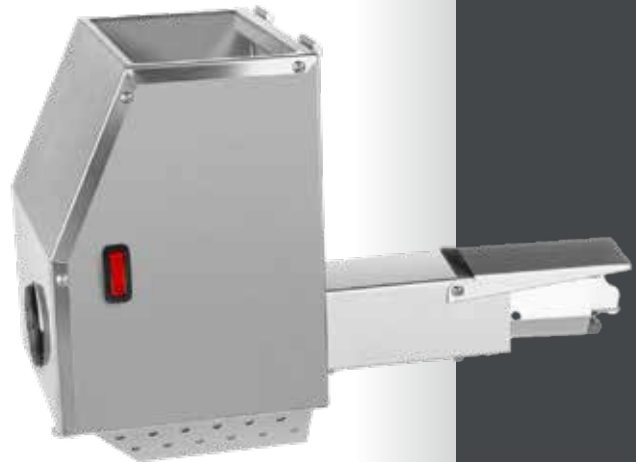

Smoking chips

The type of smoke chips significantly affects the taste, aroma and color of the smoked dish. Like spices, they depend on the type of wood. Some taste better with fish, others with pork or poultry.

Mixing different smoke chips together is also great fun, which gives you the opportunity to prepare your own recipes. However, one should not forget that the smoking chips must be natural, without chemical additives, dust and dirt.

Beech

Gives the food a bright, golden colour.

Perfect for beginners.

Ideal for pork, fish and poultry.

Oak

Classic for US style food with a noticeable hint of bitterness and caramel.

For smoking all types of meat and fish.

Maple

A medium strength, richly flavoured hardwood with a slight sweetness, maple produces a lovely mellow smoke flavour which works well with pork and poultry and is also excellent with more delicate fish flavours such as Trout.

Apple

Gives food a beautiful, golden colour.

Sweet, fruity and delicate in taste.

Ideal for pork.

Alder

Its unique aroma penetrates deep into the food and gives it a beautiful colour, from dark gold to brown

For smoking all types of meat and fish.

Birch

Imparts a mild, sweet flavor to the food. It is particularly suitable for smoking poultry, pork and fish, e.g. Salmon.

Cherry

A lightly sweet flavor bouquet with a fruity aroma. It adds a delicate bitterness and creates a reddish/brown colour on the food. Perfect for poultry.

Plum

Plum wood gives the dishes a hint of sweetness and a slight fruity aroma.

It creates a beautiful shine on the surface of the smoked meats.



Packaging available
2l, 10l, 50l

Approximate smoking time

The smoke generator's container is large enough to produce smoke for up to 8 hours after being filled with wood chips, without the need for refilling. What will you do in your spare time?

Package capacity	Approximate smoking time
2 L	8h
10 L	40h
50 L	200h



Accessories





S Hooks



S Hooks
asymmetric



Double Hooks



Hooks type -20



Hooks type -21



Hooks type -25



Cover for smokers



Food dryer for
smokers



Grate for Borniak



Strong grate for Borniak



Wheels for Borniak



Smoker tray



**Cold Smoke Adapter -
Alu-Zink**



**Cold Smoke Adapter - stainless
steel**

**Cold Smoke
Connector**



Spices

Magic Dust

Magic Dust spice is ready for all Slow Food dishes - Pulled Pork, Brisket, Ribs, Pastrami ...

Rub everything with it! It is great for pork, chicken, shrimp, steak, kebab and more.

Everyone loves to grill - now food cooked outdoors can be even tastier, just sprinkle your meat a few hours before grilling and let the delicious flavors penetrate into the meat.

You cook at home? - try adding a pinch to homemade hamburgers or meatballs. We even add it to tomato sauces to enrich their flavor.

Our grill "allrounder" is a real taste sensation. We based the recipe on the American version of Mike Mills. In the USA, "Magic Dust" is probably one of the best-known recipes for a spice mix, perfect for grilling but also for smoking and frying.



Pitmasters Pride

Pitmasters Pride is a combination of a classic blend of extraordinary BBQ spices with a hint of herbs. A spice that surprises with a variety of flavor accents - it was rated best in the "blind test" for a reason.

Pitmasters Pride spice is ready for all Slow Food dishes - Pulled Pork, Brisket, Ribs, Pastrami ...

Rub everything with it! It is great for chicken wings, pork, steak and more.

Everyone loves the grill - now meals cooked outdoors can be even tastier. Just sprinkle your meat a few hours before grilling and let the delicious flavors seep in.

You cook at home? - try adding a pinch to homemade hamburgers or meatballs. And even with tomato sauces to enrich their flavor!

Pitmasters Pride is a hint of crazy flavors and a sharp kick to any type of food.



Fish Hunter

The Fish Hunter spice is a simple way to prepare fish in a traditional way. We have created the brine for a unique taste. Using it will allow you to smoke trout, mackerel and many others with ease, producing golden, delicate and juicy fish.



Specyfikacja

EAN	5902114271503	Classic Smoker 70 SIMPLE	5902114271572	Classic Smoker 70 TIMER	5902114271534	Smoker 70 BBQ INOX SIMPLE	5902114271558	Smoker 70 BBQ INOX TIMER	5902114271510	Classic Smoker 150 SIMPLE	5902114271565	Classic Smoker 150 TIMER	5902114271527	Smoker 150 BBQ INOX SIMPLE	5902114271541	Smoker 150 BBQ INOX TIMER
SKU	UWD-70	UWDT-70	UWDT-70	BBDS-70	BBDS-70	BBDST-70	BBDST-70	BBDST-70	UWD-150	UWD-150	UWDT-150	UWDT-150	BBDS-150	BBDS-150	BBDST-150	BBDST-150
Chamber capacity	70 L															
Controlling	SIMPLE															
Finish material	Alu-Zink															
Maximum Operating Temperature	120°C															
Rated voltage	230 V															
Device power	615 W															
Number of levels	6															
Maximum load	10kg (7kg Sausages)															
Internal dimensions (LxWxH)	70 L (30 x 40 x 59 cm)															
Dimensions (LxWxH)	40 x 63 x 100 cm															
Weight	25 kg															
Guarantee	24 months															

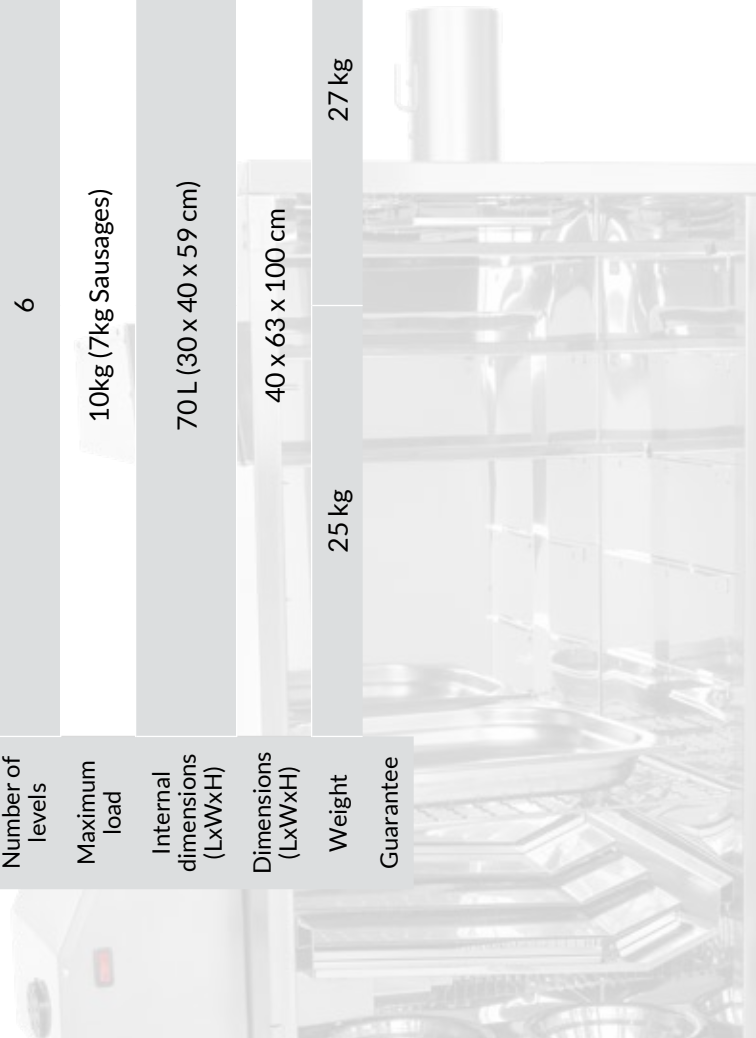







Borniak

ul. Al. Niepodległości 41
78-449 Borne Sulinowo, Poland
info@borniak.com
www.borniak.com

(+48) 94 716 22 29
(+48) 94 373 00 02
info@borniak.pl
www.borniak.pl

(+49) 322 210 964 95
(+49) 322 217 886 21
info@borniak.de
www.borniak.de

(+44) 744 1429 450
(+48) 94 716 22 29
info@borniak.co.uk
www.borniak.co.uk